



# DEI MARINE

PROVEN, FAIL-SAFE GALVANIC ISOLATION

## The Marine Galvanic Isolator (GI) Technical Literature

### 30A



Galvanic Isolators

### 50/60A

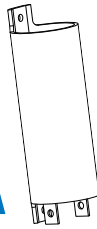

Galvanic Isolators

### 100A

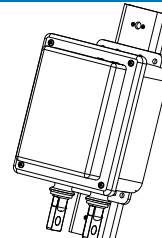

Galvanic Isolators

### 200A

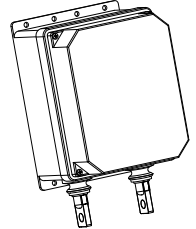

Galvanic Isolators

### INTRODUCTION

The DEI Marine Galvanic Isolator (GI) is a fail-safe, solid-state DC isolation/ AC coupling device for marine applications with exceptional product performance and certifications to ABYC A-28. Galvanic isolators are desirable whenever a boat is connected to AC shore power, due to a galvanic circuit, which can cause corrosion of the boat and its drive system components. Due to the difference in the potential of the hull and drive system metals compared with the shore grounding system or other boats, a galvanic current, which causes corrosion, can flow. A galvanic isolator is installed in series with the shore power cable grounding conductor to prevent the flow of galvanic current thereby preventing galvanic corrosion. A typical installation schematic is shown in Figure 5.

#### Fail-Safe Criteria

In the marine industry, the criteria for galvanic isolators is defined by the American Boat and Yacht Council (ABYC) recommended standard A-28. Due to recommendations to the A-28 galvanic isolator committee about the need to retain safety grounding under all conditions, as required by the U.S. National Electrical Code for all similar applications outside of A-28, the standard makes provision for "fail-safe" galvanic isolators. To be considered "fail-safe," an independent laboratory must confirm that the isolator will either remain fully functional or remain a permanent, effective grounding path if it fails, when subject to the ultimate current-carrying capability of the grounding conductor (i.e. the energy required to melt the conductor).

This important safety feature eliminates the need for a monitoring system, which is no longer required for fail-safe units because the safety concerns of a product compromising the grounding conductor have been removed.

### PRODUCT OVERVIEW

DEI Marine manufactures fail-safe Galvanic Isolators, which have been tested and certified to ABYC A-28 publication, by Imanna Laboratory, Inc.

Our extensive experience with solid-state grounding devices and "decouplers" dates back to 1983, manufacturing conservatively designed products for high power applications in the power utility, pipeline, and railroad markets. Dairyland manufactures isolators for other industries that have identical construction to the Galvanic Isolator line, and which have been fully tested and listed by Underwriters Laboratories to US and Canadian electrical codes (NEC, CSA, etc) for safety grounding and suitability for hazardous locations. The units were further tested by UL/Demko to meet European requirements. These electrical codes are much more demanding than the ABYC A-28 standard, where fail-safe construction is not optional, but required. All DEI Marine Galvanic Isolators are considered "Fail-Safe Plus®" or "Fail-Safe MAX®," defined in the following sections.

DEI Marine offers Galvanic Isolators rated 30A, 50/60A, 100A, and 200A. The scope of A-28 covers ratings through 100A, but the 200A model has similar construction to the certified models, with a full 200A continuous current rating (plus overload margin per ABYC).

#### Fail-Safe Plus®

Fail-Safe Plus models not only meet the fail-safe test criteria in A-28, but also have considerably higher AC fault current ratings than are required and have substantial lightning current ratings which are not required by A-28.

#### Fail-Safe Max®

Fail-Safe Max models provide even higher performance than Fail-Safe Plus models, in that they have higher fault current ratings and will still be fully functional and meet all requirements of A-28 after being subject to the fail-safe test criteria (i.e. the energy required to melt the conductor).

### Did You Know?

All DEI Marine products are certified and exceed ABYC A-28 requirements. In fact, DEI Marine was responsible for introducing fail-safe design in galvanic isolators to the marine industry.

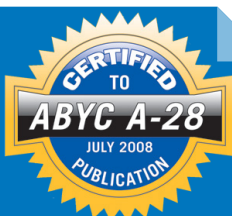

## Key Features

- Verified Fail-safe construction
- Highest AC fault current ratings
- No monitoring system required per ABYC A-28
- Rated for lightning current. No other known galvanic isolators have published lightning current ratings

## Additional Unique Features

- Ignition protected
- Optional “Fail-Safe Max” ratings
- Longest warranties offered in the industry
- Certified to ABYC A-28 as “Fail-Safe”
- Compact design
- Designed for cool operation - no heat sinks needed
- Prevents the flow of galvanic current with super imposed AC current well above the 3A minimum required by A-28
- Designed to meet stringent NEC land-based grounding requirements (exceeds marine requirements)

## PRODUCT CAPABILITIES

### Blocking Voltage

Per ABYC A-28, the DEI Marine model GI family has a DC blocking voltage of at least 1V. At a voltage below this value, the GI blocks the flow of DC current and allows AC current to pass. At voltages above the blocking voltage, such as could occur from an AC fault or lightning, the GI is a bi-directional conduction device that readily allows all current to flow, thereby safely limiting the voltage on the boat.

### System Voltage

DEI Marine Galvanic Isolators are strictly current rated and can be used on any voltage class system. Since A-28 requires a system voltage rating on the nameplate, all DEI Marine Galvanic Isolators are name-plated for use on systems of 600Vac or less.

### DC Leakage Current

For a given DC voltage across the GI, there will be a small DC leakage current. This value will be negligible (less than 1mA) at the worst-case galvanic voltage difference anticipated across the device, and well below the limits in ABYC A-28. The leakage current is a corrosion-causing current that is minimized with the DEI Marine design.

### Steady-State AC Current

Galvanic isolator models are rated to carry the steady state AC current for which the shore power cable is rated. The ratings offered by DEI Marine are 30A (which has been certified and nameplated for 35A continuous to satisfy European requirements for a 32A rating), 50/60A (for a single 50A shore cord or two 30A shore cords), 100A (for a single 100A shore cord or two 50A shore cords), and 200A (for a single 200A shore cord or two 100A shore cords).

### Exceptions:

If the shore power steady-state current rating is different from

the above values, choose a GI rating that exceeds the shore power rating. When in doubt about ratings, contact DEI Marine.

### AC Fault Current

All DEI Marine Galvanic Isolators are designed to exceed the ABYC A-28 ratings for AC fault current. When a boat is connected to shore power, if a fault on the boat occurs, the isolator will be exposed to fault current until the appropriate breaker operates. DEI offers models that have assured fail-safe operation, based on testing to the equivalent failure level of the shore power cable grounding conductor required for a given current rating. An even higher level of performance and protection is offered in the “Fail-Safe Max” line, with units that remain fully functional after being exposed to the fail-safe isolator test criteria in A-28. Following are the fault ratings of all DEI models, in amperes rms symmetrical, for both the Fail-Safe Plus and Fail-Safe Max classes. For comparison, per the A-28 standard, non-fail-safe galvanic isolators are only required to be tested for one cycle at the fault current ratings shown below, for three consecutive times. DEI marine products greatly exceed all requirements.

AC Fault Current Ratings (Amps AC-RMS Symmetrical)		
Model	Fault Rating	Product Class
GI-30A-FSP	3kA for 13 Cycles	Fail-Safe Plus
GI-30A-FSM	3kA for 34 Cycles	Fail-Safe MAX
GI-50/60-FSP	5kA for 10 Cycles	Fail-Safe Plus
GI-50/60-FSM	5kA for 31 Cycles	Fail-Safe MAX
GI-100-FSM	10kA for 198 Cycles	Fail-Safe MAX
GI-200-FSM	5kA for 198 Cycles	Fail-Safe MAX

### Lightning Surge Current

Although not a requirement of A-28, DEI Marine has established substantial lightning current ratings for all Galvanic Isolators. The lightning surge current rating should not be confused with the AC fault current rating. Lightning has a very different waveform, with a faster rise time, a shorter duration, and much less energy than for an AC current waveform of the same peak current. However, lightning develops much larger voltage differences along the current flow path than AC, resulting in arcing, equipment damage, or personnel risks. Lightning current ratings for DEI Marine Galvanic Isolators were established by subjecting the galvanic isolator to representative lightning current in a high power test laboratory per the requirements of ANSI C62.11. The waveform used for DEI Marine testing is described as an industry standard 4x10µs waveform. This describes a lightning waveform where the rise time is 4 microseconds to peak value, followed by decay to one-half of peak in 10 microseconds. The following models have the peak current rating stated.

## Lightning Surge Current Rating

Model	Fault Rating	Product Class
GI-30A-FSP	75kA Peak	Fail-Safe Plus
GI-30A-FSM	100kA Peak	Fail-Safe MAX
GI-50/60-FSP	100kA Peak	Fail-Safe Plus
GI-50/60-FSM	100kA Peak	Fail-Safe MAX
GI-100-FSM	100kA Peak	Fail-Safe MAX
GI-200-FSM	100kA Peak	Fail-Safe MAX

## FEATURES AND CHARACTERISTICS

### Certification

The DEI Marine line of Galvanic Isolators was tested and certified by Imanna Laboratory, Inc of Rockledge, FL to the ABYC A-28 standard, July 2008 publication. As defined in the standard, all DEI Marine products are “Ignition Protected” and “Fail-Safe,” or beyond the requirements of fail-safe as previously described (i.e., Fail-Safe Plus and Fail-Safe Max).

\* Note: While ABYC A-28 standards do not specify requirements for a 200A device, DEI’s 200A Galvanic Isolator was tested to the criteria that would apply if the requirements of A-28 were extended to this rating.

### Solid-State Design

The DEI Marine Galvanic Isolator utilizes solid-state components in proven designs supplied to the energy industries since 1983. The design has an instantaneous response to voltage, initiating voltage clamping immediately when the voltage attempts to exceed the blocking level. The design includes a non-polarized capacitor. All DEI Marine products are fail-safe by design.

### Warranty

Due to the conservative design, DEI Marine offers long term warranties. The warranty for a Fail-Safe Plus class product is 7 years, and for a Fail-Safe Max class product is 10 years. During the warranty period, any model will be repaired or replaced due to failure for any cause.

### Field Testing/Maintenance

The Galvanic Isolator can be field tested with a multi-meter and clamp on DC ammeter. Testing procedures are included in the installation instructions. The Galvanic Isolator is completely maintenance-free.

### Enclosure

The 30A and 50/60A models are packaged in a molded, non-metallic enclosure rated IP68. See Figure 1 and 2. The 100A and 200A models are packaged in a molded, non-metallic fiberglass enclosure rated NEMA 4X. See Figures 3 and 4.

### Polarity/Electrical Connection

The Galvanic Isolator terminals do not include polarity marks because it is bi-directional and symmetrical in design. However, the terminals are marked as “Boat Ground” and “Shore Ground” to avoid confusion or inadvertent bypassing of the

device. Conductors are to be terminated with one-hole cable lead connectors (user furnished) by bolting, using the hardware supplied by DEI Marine. The connector should be sized for a 5/16” diameter bolt for 30A and 50/60A models, and for a 1/2” diameter bolt for the 100A and 200A models. Torque values are included in the installation instructions.

### Number of Operations

The number of times that the Galvanic Isolator can be subject to its rated lightning or AC fault current rating is virtually unlimited, provided the operations are not immediately repetitive.

### Energy Requirements

None. The device is completely passive.

### Ambient Operating Temperature

-45°C to +65°C

## Did You Know?

The fail-safe characteristics of DEI Marine Galvanic Isolators remove the safety concern of a galvanic isolator compromising the grounding conductor, eliminating the need for monitoring, per ABYC A-28. Monitoring will still be required for isolators made by others that are not certified as fail-safe.

1 Galvanic Isolator Outline Drawing for 30A Model

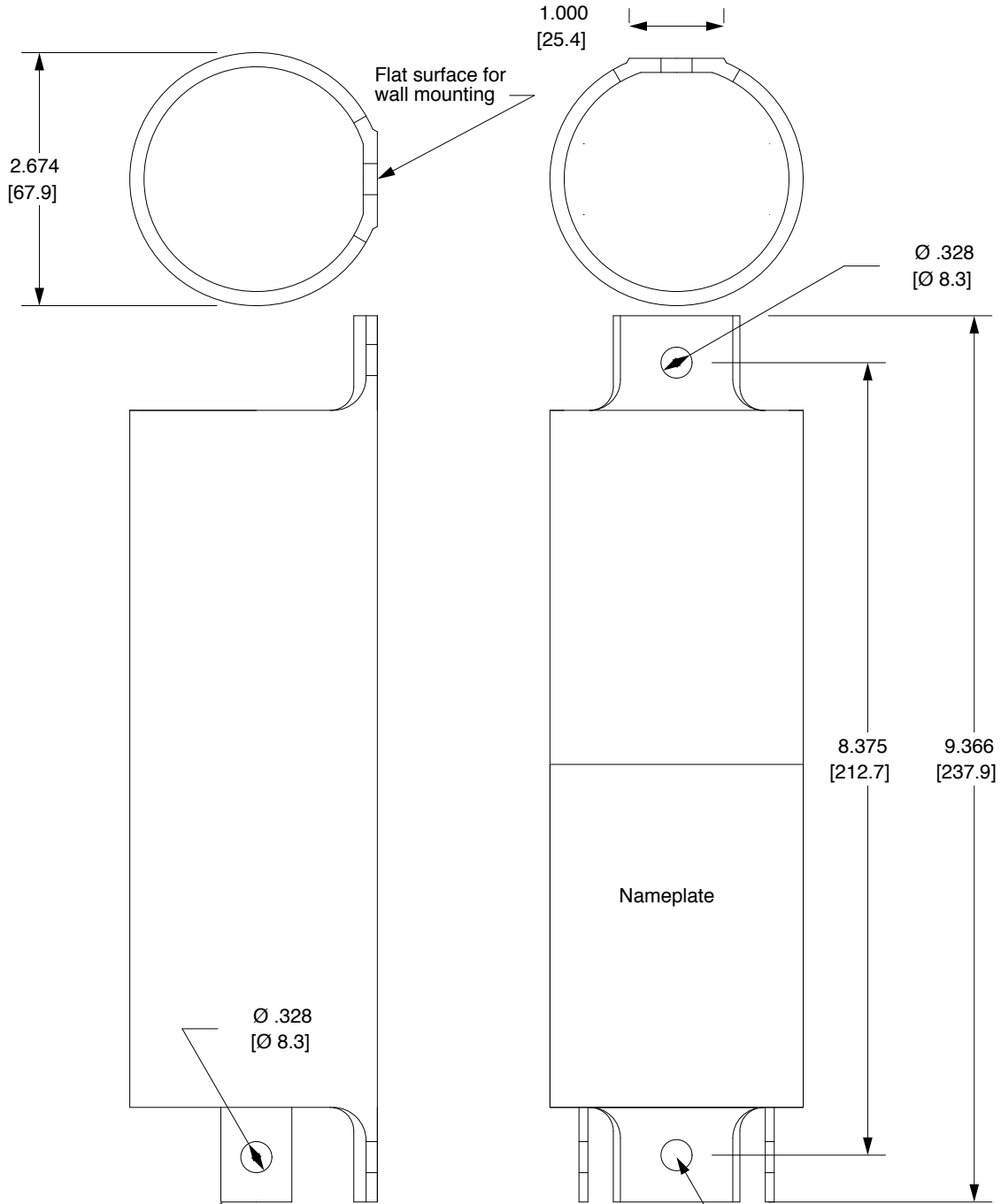

0.094" x 0.75" (3.39mm x 19.1mm) terminals with 5/16 stainless bolts, nuts, and washers furnished.)

5/16" or M8 mounting bolts - user furnished. Allow for 0.150" thick mounting flange. Use flat washer (provided) under bolt head.

**2 Galvanic Isolator Outline Drawing for 50/60A Models**

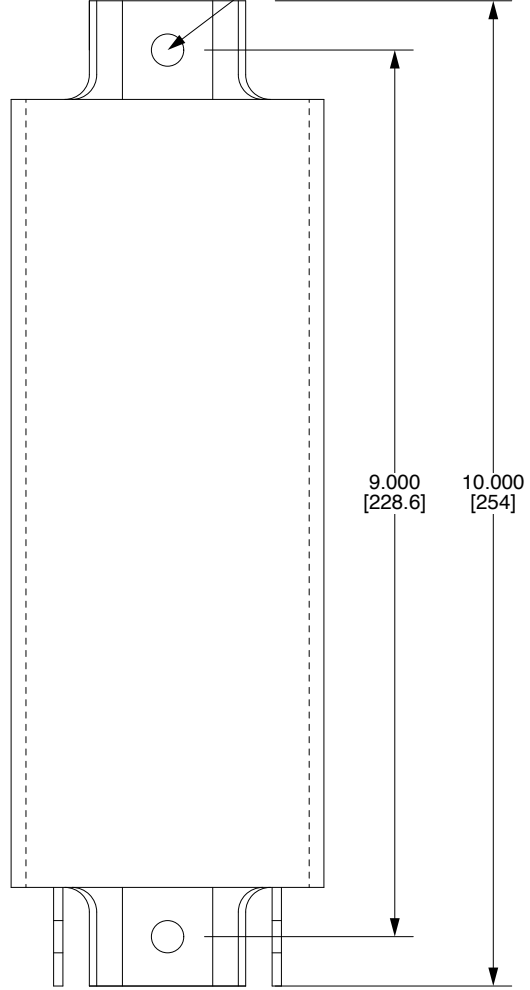
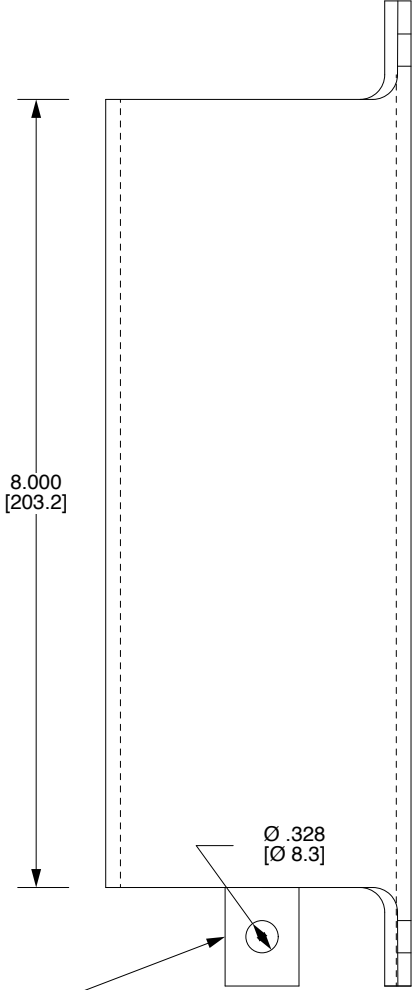
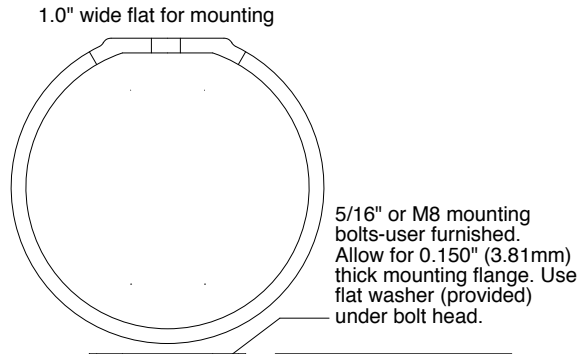
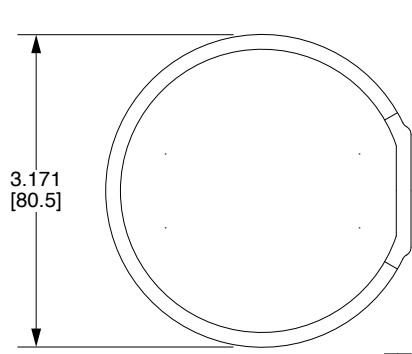

0.094" x 0.75" (3.39mm x 19.1mm) terminals with 5/16" stainless steel bolts, nuts, and washers furnished.

### 3 Galvanic Isolator Outline Drawing for 100A Model

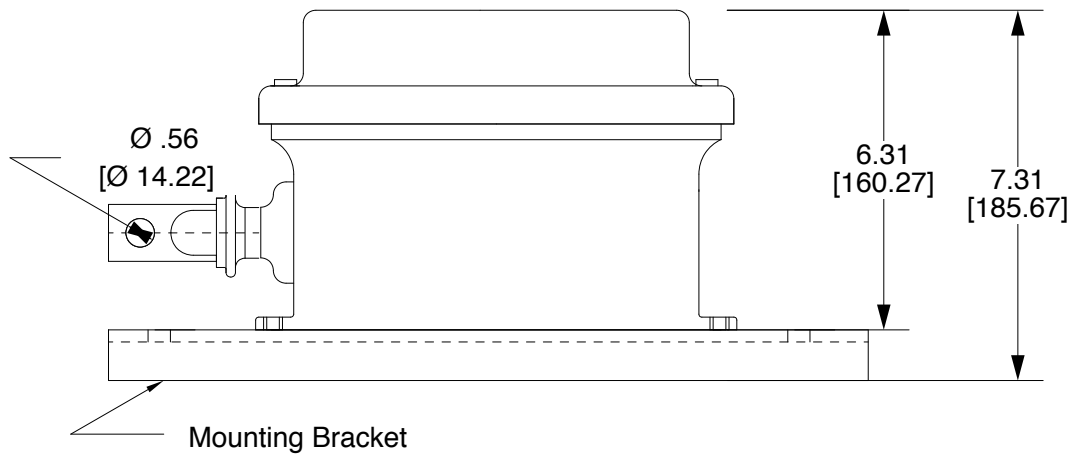
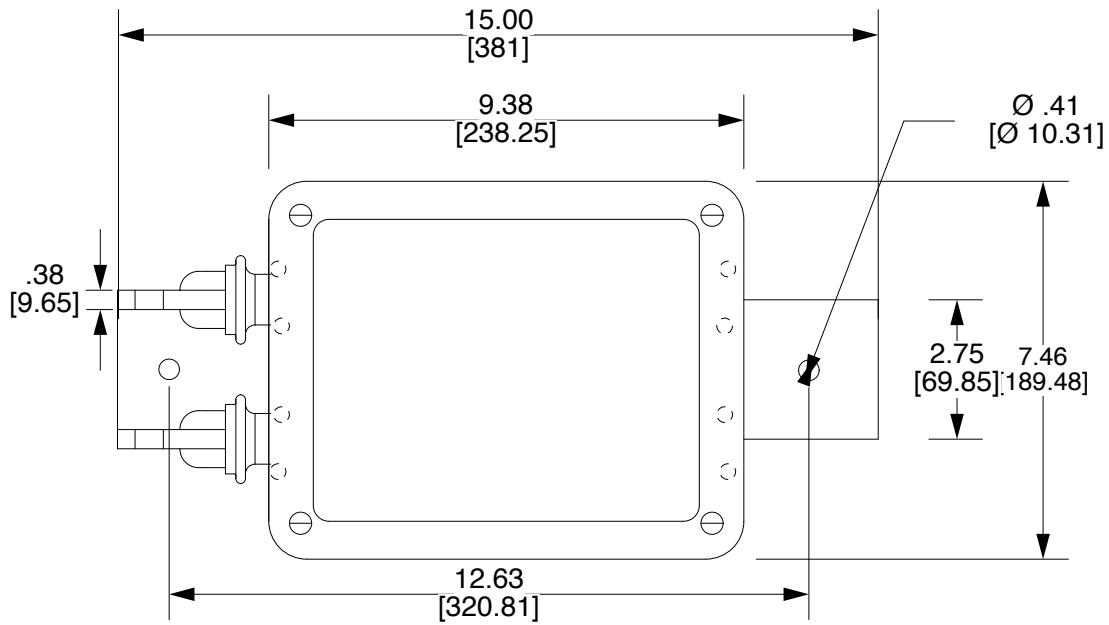

#### Note:

1. If desired, the mounting bracket furnished can be removed and the galvanic isolator can be mounted using the flanges on the enclosure. Four inner mounting holes are located on 1.75" x 8.75" centers and four outer mounting holes are located on 4" x 8.88" centers.
2. Mounting with the bracket provided requires (2) 3/8" (10mm) bolts and mounting by using the enclosure flange requires (4) 1/4" (6mm) bolts - user furnished.
3. Terminal bolts (1/2" diameter) are furnished with nuts and washers, not shown.
4. Compression connectors for leads - user furnished.
5. Dimensions in inches and millimeters.

#### 4 Galvanic Isolator Outline Drawing for 200A Model

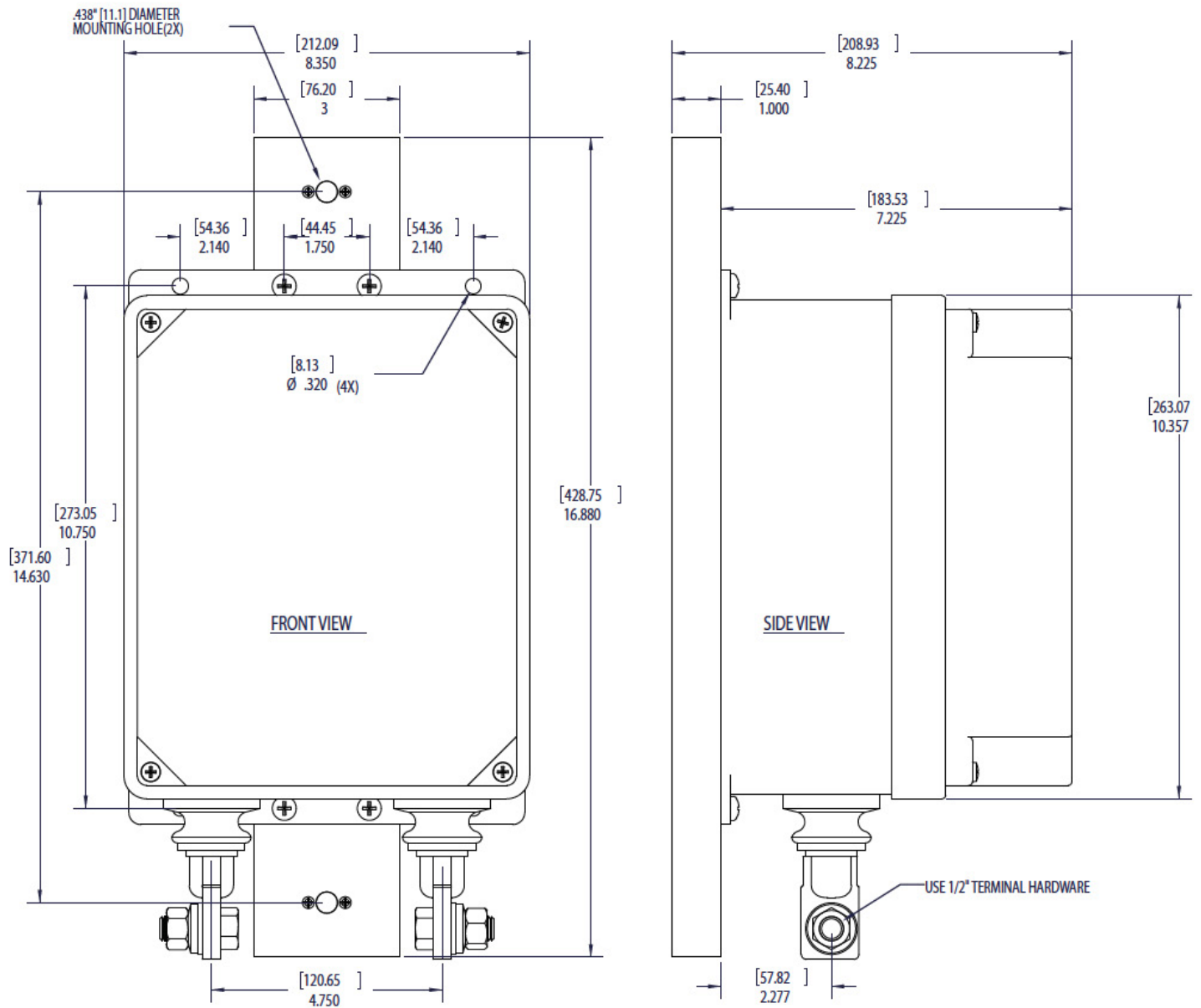

1. The furnished C-Channel Mounting Bracket may be removed and the Galvanic Isolator can be mounted using the flanges of the enclosure and the dimensioned mounting holes.
2. Mounting with the C-Channel requires (2) 3/8" (10mm) bolts, mounting with the Enclosure Flanges requires (4) 1/4" (6mm) bolts - user furnished.
3. Terminal Bolts (1/2") are furnished with nuts and washers (not shown).
4. Compression Connectors for leads are user furnished.
5. Dimensions in millimeters and inches.



**5 Typical Installation of a Galvanic Isolator for Marine Vessel Application**

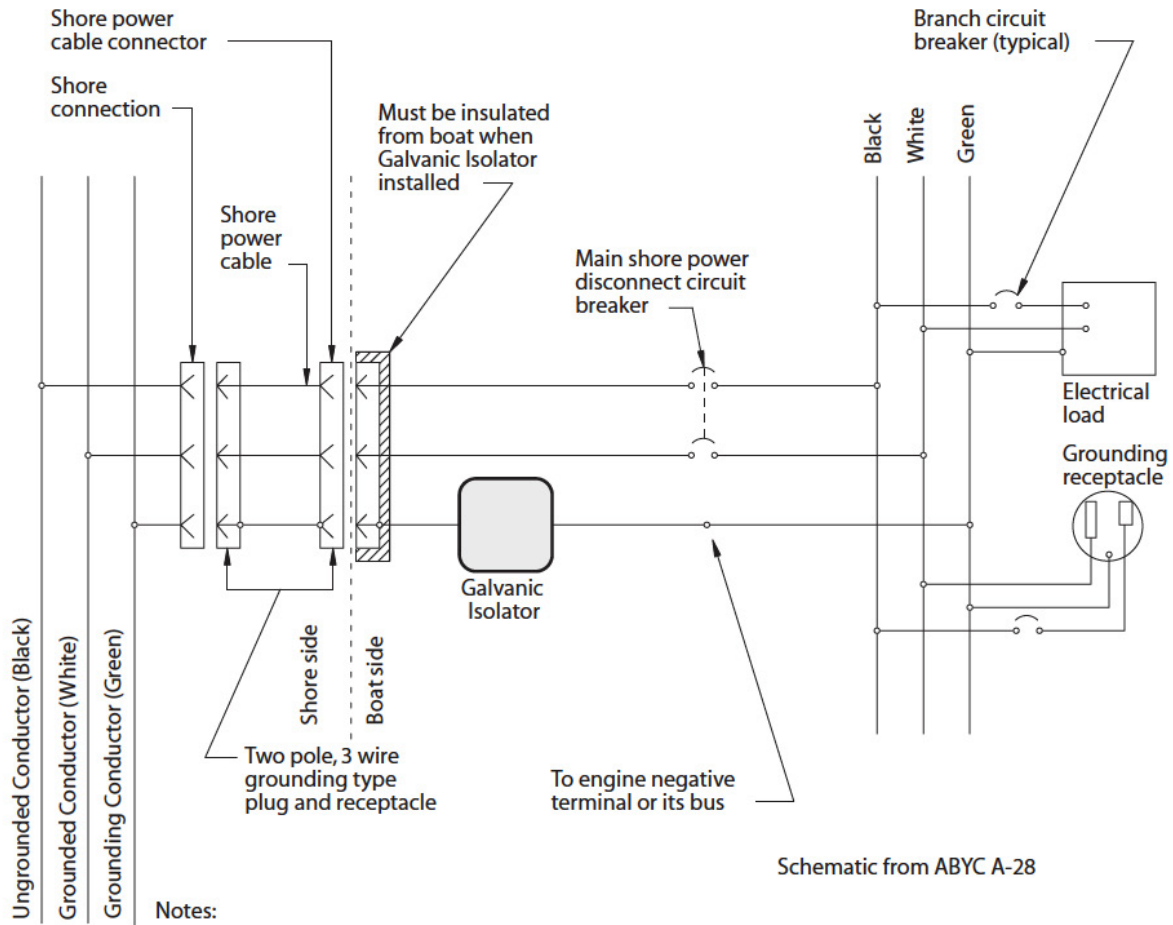

Schematic from ABYC A-28

**Notes:**

1. For installation of the Galvanic Isolator in other common electrical services, refer to ABYC Standard E-11, "AC and DC Electrical Systems on Boats" or contact DEI for assistance.
2. Applies to comparable single-phase or three-phase AC systems of any voltage class which utilize a separate grounding conductor.